

Figure 0343 Scupper Installation Instructions

With 2 to 4-3/4 Inch Adjustment, Impact Installation

PLEASE READ ALL INSTRUCTIONS BEFORE PROCEEDING

PERKO® Scupper Figure 0343 is intended to be mounted in a 1-7/8" hole on surfaces from 2" to 4-3/4" thick, and located above the water line. The flange on the inboard side of the scupper should be as close as possible to the cockpit sole. The scupper valve portion must be mounted outboard with the "flapper" attachment screw on top.

After drilling the 1-7/8" mounting hole, measure the thickness of the mounting surface. If the thickness is less than 4-3/4", the neck of the inboard (female) portion of the scupper can be cut down by one rib for each 1/4" difference between the actual hull thickness and 4-3/4". This ensures that the distance between the scupper flanges is slightly less than the hull thickness, so that the scupper will fully clinch before bottoming out.

A sealant appropriate for use near the water line should be applied to the outside of the tube of the outboard (male) part, and around the underside of the flanges for both parts.

Either inboard or outboard part may be installed first. A block of wood or other protective means should lay flat against the outside flange and the part can be driven in with a few blows of a mallet. The first part installed should be braced, while the second part is driven in.

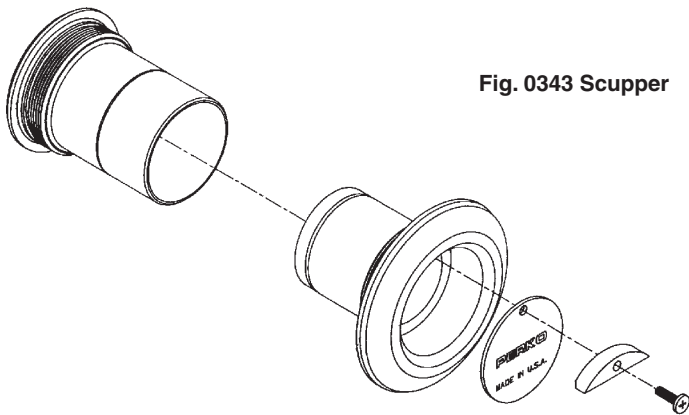

Fig. 0343 Scupper